

Project Name: _____ AIA#: _____

Model #: _____ Location: _____

SIS#: _____ Item #: _____ Quantity: _____



80 Quart Planetary Floor Mixer

*The Perfect Mix of Value,
Performance & Durability*

*Features front mounted touch pad control
panel with 60-minute digital timer!*



Model

SPC80PL

Standard Features

- Powerful 3 HP custom built motor
- Gear-driven, high-torque transmission
- Heat-treated hardened steel alloy gears & shafts
- Four fixed speeds
- Oil bath transmission
- Thermal overload protection
- Front-mounted touch pad controls with 60-minute digital timer and last-batch recall
- Stainless steel, interlocking bowl guard with built-in fully welded ingredient chute
- Heavy duty bowl truck (pictured)
- Power bowl lift
- Rigid cast iron body
- Industry standard #12 attachment hub
- NSF approved enamel gray paint
- 6-foot cord and ground plug
- Automatic safety shut off, provides superior motor and transmission protection

Standard Accessories/Attachments

- 80 qt. stainless steel bowl (#304 series)
- Aluminum flat beater
- Stainless steel wire whip
- Aluminum spiral dough hook
- Non-slip rubber feet
- Bowl truck

Warranty

- Two years parts and labor

Optional Attachments/Accessories

- Seismic flange kit
- Vegetable slicer for #12 hub
- Shredder/grater for #12 hub
- Meat grinder for #12 hub
- Meat tenderizer for #12 hub
- Strip cutter for #12 hub
- Aileron (wing) whip
- 40-qt. adapter kit
- 60-qt. adapter kit
- Bowl scraper
- Correctional package

To select options, see complete list on back

Approved by: _____ Date: _____



AutoQuotes



80 Quart Planetary Floor Mixer

SPC80PL

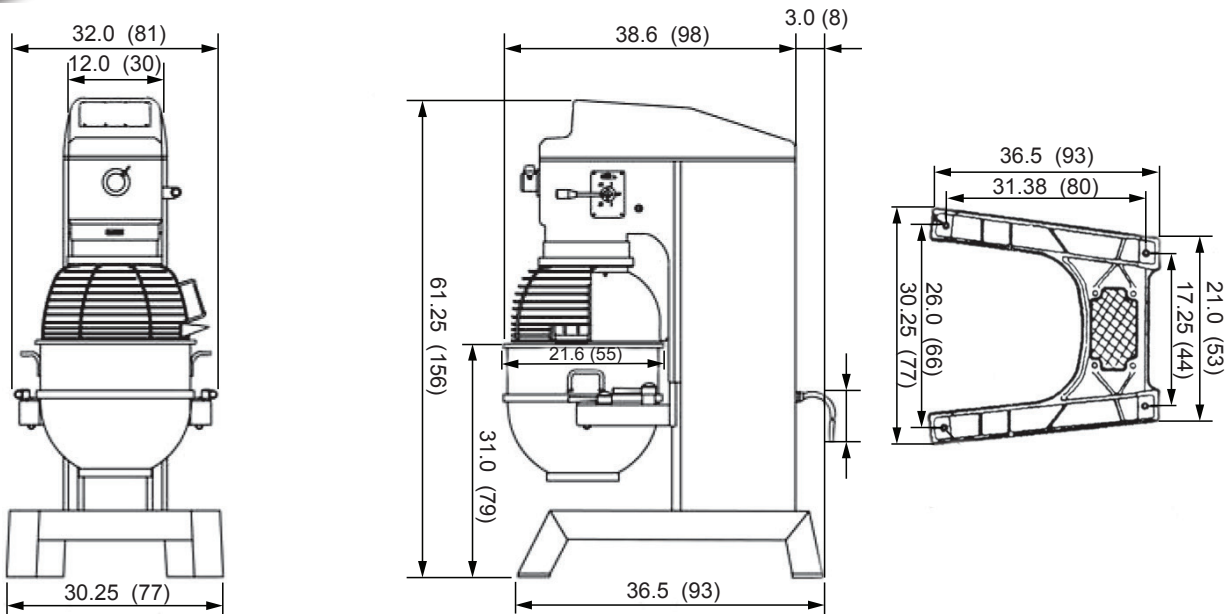

UNIT: INCHES (CM)

Drawings available through KCL at www.kclcad.com.

SPECIFICATIONS

Model	Motor	Volts	Amps	Transmission Type	Capacity	Controls	Power Bowl Lift	Agitator Speeds (RPMs)		Attachment Speeds (RPMs)	
								First	Second	First	Second
SPC80PL (3 Phase)	3 HP	208/60/3	12	Gear	80 qt 75.7 liter	Digital, front mounted timer & controls	1/8 HP Motor	60	105	67	118
								Third	Fourth	Third	Fourth
								176	310	198	349

DIMENSIONS | SHIPPING INFORMATION

Cartons are reinforced for shipping. The weight and dimensions of this reinforced carton are included below and may vary from shipment to shipment. **This product ships on a pallet. Freight class 85.**

Model	Base Foot Print	Overall Dimensions	Net Weight	Shipping Dimensions	Shipping Weight
SPC80PL	30.25" W x 36.5 D (77 cm x 93 cm)	30.25" W x 38.6" D x 62" H (77 cm x 98 cm x 156 cm)	1,003 lbs (455 kg)	48" W x 48" D x 76" H (122 cm x 122 cm x 193 cm)	1,270 lbs (575 kg)

Mixer is constructed of a rigid cast iron body with front-mounted touch and 60-minute digital timer with last-batch recall. Mixer has 3 HP custom built motor with overload protection and gear-driven, high torque permanently lubricated transmission consisting of heat-treated hardened steel alloy gears and shafts. Mixer comes with 80 qt. stainless steel bowl, aluminum flat beater, stainless steel wire whip, bowl truck, aluminum spiral dough hook and non-slip rubber feet. Interlocked with stainless steel bowl guard with fully welded ingredient chute. Mixer has #12 attachment hub and interlocked bowl lift. Mixer is NSF and ETL listed. Two-year parts and labor warranty.

OPTIONAL MIXER ACCESSORIES AND HUB ATTACHMENTS

- MIXER:**
- XXSEISMIC KIT-LG** Seismic kit
 - XXBOWL-80** 80 qt stainless steel (S/S) bowl
 - XXBEAT-80** Alum. flat beater
 - XXBEAT-80SS** S/S flat beater
 - XXHOOK-80** Alum. dough hook
 - XXWHIP-80** S/S wire whip
 - XXHDWHIP80-4** Heavy-duty 4 mm S/S wire whip
 - XXAWHIP-80** 80 qt aileron whip
 - XXSCR-80** scraper with mounting kit
 - XXACC40-80** Adapter kit - 40 qt bowl, hook, beater and whip
 - XXACC60-80** Adapter kit - 60 qt bowl, hook, beater and whip
- HUB:**
- XVSGH** 9" Slicer/Shredder/Grater housing only (no plates included-must select from plates listed on this sheet)
 - XASP** Adjustable slicing plate (for vegetables only)
 - XPH** Plate holder - *only 1 required
 - L00670** Meat Tenderizer attachment
 - L00783** Strip Cutter attachment
- Shredding Plates:**
- XSP332*** 3/32" (2.3 mm)
 - XSP316*** 3/16" (4.7 mm)
 - XSP14*** 1/4" (6.3 mm)
 - XSP516*** 5/16" (7.9 mm)
 - XSP12*** 1/2" (12.7 mm)
 - XGP*** Grating plate
 - XMCA-SS** Meat grinder assembly (Polished stainless steel cylinder, worm gear, ring, and s/s pan. Includes knife, 3/16" plate, and pusher)
 - XXCK** Chopper knife for XMCA-SS
- Chopper Plate Sizes Available:**
- CP02-12** 1/16" (2 mm)
 - CP04-12** 5/32" (4 mm)
 - CP05-12** 3/16" (5 mm)
 - CP06-12** 1/4" (6 mm)
 - CP08-12** 5/16" (8 mm)
 - CP10-12** 3/8" (10 mm)
 - CP12-12** 1/2" (12 mm)
 - CP14-12** 9/16" (14 mm)
 - CP16-12** 5/8" (16 mm)
 - CP18-12** 11/16" (18 mm)
 - CP00-12** Stuffing plate
 - XST12** 1/2" Stuffing tube (mutton)
 - XST34** 3/4" Stuffing tube (pork)
- FACTORY INSTALLED OPTION:**
- XXCORR-80** Correctional package, includes tamper resistant external fasteners.